

AB60JRT

ARTICULATED BOOM LIFT



- Tough & reliable diesel articulated boom lift
- Powerful 4 wheel drive for rough terrain
- Robust, rental tough design
- Simple to operate and maintain
- Ideal for both maintenance and construction applications

 **snorkel**
www.snorkellifts.com

ARTICULATED BOOM LIFT

AB60JRT

DIMENSIONS	AB60JRT
Max. working height	20.3m
Max. platform height	18.3m
Max. horizontal reach	13.1m
Platform size	1.5m x 0.76m
Overall width (A)	2.4m
Overall length (B)	8.9m
Stowed height (C)	2.5m
Ground clearance	300mm

PERFORMANCE	
Platform capacity (SWL)	227kg
Max. drive height	18.3m
Max. drive speed (stowed)	4.8 km/h
Max. drive speed (elevated)	0.5 km/h
Jib length	1.8m
Jib working arc	75°
Platform rotation	180°
Raise/lower time	132/123 sec
Gradeability	20%
Inside turning radius	2.6m
Tyres	15 x 19.5 loader lug foam filled
Controls	proportional joystick drive, lift & rotation
Drive system	4 wheel drive

POWER	
Power source	3.3 litre water cooled diesel 65hp

WEIGHT	
Gross weight	11,249kg

WORKING ENVELOPE

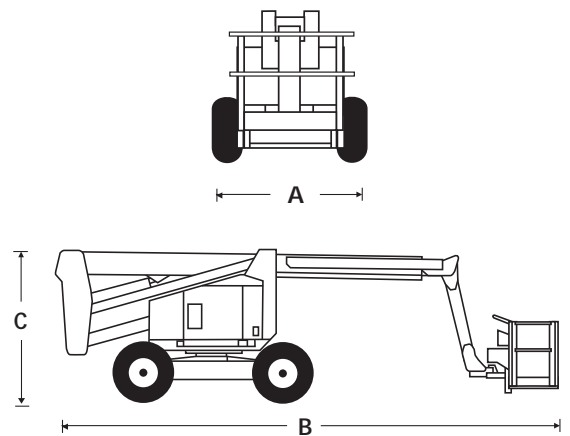
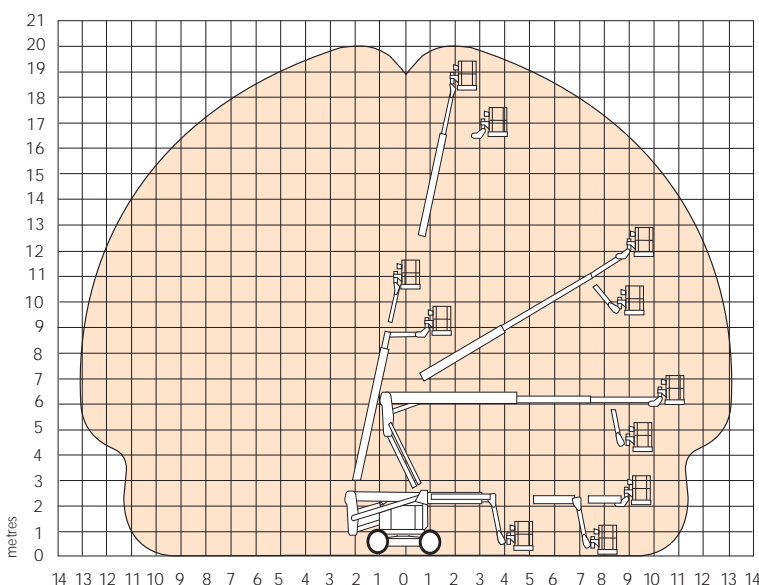

STANDARD FEATURES

- 1.8m, 75° jib
- Hydraulic powered platform rotation
- 4 wheel drive
- Proportional control of drive, boom lift and rotation
- Foam filled lug tyres
- Amber beacon
- Operator horn
- CE approved

OPTIONS

- Hydraulic generator
- Airline to platform
- Swing gate
- Cold weather package
- Extreme cold weather package
- Light package
- Extreme environment package
- Aircraft package
- Tow package
- Glazier package
- Drive motion alarm

snorkel www.snorkellifts.com

2/26 Redfern Street,
Wetherill Park,
NSW 2164, Australia
t: +61 1300 900 700

e: sales.au@snorkellifts.com