



Rough Terrain Self-propelled Scissor Lift

GS™ 2668 RT
GS™ 3268 RT

Reliable rough terrain
scissor lifts with superior
gradeability and standard
four wheel drive.



Standard Features

- The GS-2668 RT has a 9.8 m (32 ft) working height and the GS-3268 RT has a 11.8 m (38 ft) working height
- 1.5 m (60 in) roll-out platform extension
- 1.7 m (68 in) unit width
- 567 kg (1,250 lb) load capacity on the GS-2668 RT, and 454 kg (1,000 lb) load capacity on the GS-3268 RT
- Four wheel drive
- High-speed/high-torque selector switch
- Proportional drive
- Two-speed lift functions
- Multiple disc brakes

- Manual platform lowering valve
- Tilt sensor with an audible alarm
- Emergency stop switches at platform and ground controls
- Manual brake release
- Swing-out engine tray
- Automotive horn
- Full height swing platform gate
- Foam-filled tyres
- Hour metre
- Motion alarm
- Dual flashing beacon

Options and Accessories

- Outriggers
- Air line to platform
- 2,000 watt AC generator
- Head and tail lights
- Platform work lights
- Powered deck extension
- Spare propane tank
- Pressure gauge, water temperature gauge and voltage meter

Standard Compliance

- ANSI/SIA A92.6
- CSA CAN3-B354.2-M82
- CE compliance option
- AS 1418.10

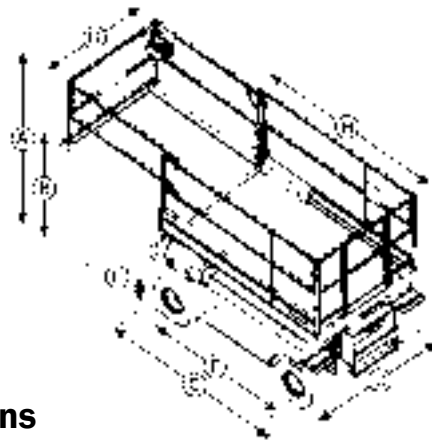

Specifications

Model	GS-2668 RT		GS-3268 RT	
	Metric	US	Metric	US
Working height	9.8 m	32 ft	11.8 m	38 ft
Platform height	7.9 m	26 ft	9.8 m	32 ft
Ⓐ Height – stowed (guardrails)	2.4 m	92 ½ in	2.5 m	97 ½ in
Height – stowed (guardrails lowered)	1.7 m	68 in	1.8 m	69 ½ in
Ⓑ Height – stowed (platform)	1.2 m	47 in	1.3 m	52 in
Ⓒ Unit length – stowed	2.7 m	105 in	2.7 m	105 in
Unit length – with outriggers	3.37 m	133 in	3.37 m	133 in
Unit length – platform extended	4.2 m	165 in	4.2 m	165 in
Ⓓ Unit width	1.7 m	68 in	1.7 m	68 in
Unit width – with outriggers	1.77 m	70 in	1.77 m	70 in
Ⓔ Wheelbase	1.9 m	73 in	1.9 m	73 in
Ⓕ Ground clearance	20.3 cm	8 in	20.3 cm	8 in
Ⓖ Platform width	1.5 m	61 in	1.5 m	61 in
Ⓗ Platform length – stowed	2.5 m	99 in	2.5 m	99 in
Platform length – extended	4 m	159 in	4 m	159 in
Roll-out platform extension	1.5 m	60 in	1.5 m	60 in
Lift capacity	567 kg	1,250 lb	454 kg	1,000 lb
Extension deck capacity	136 kg	300 lb	136 kg	300 lb
Turning radius outside	3.7 m	145 in	3.7 m	145 in
Turning radius inside	1.5 m	60 in	1.5 m	60 in
Power source	Kubota 23 HP Gas/LPG Kubota 20 HP diesel		Kubota 23 HP Gas/LPG Kubota 20 HP diesel	
Drive speed – stowed	6.1 km/h	3.8 mph	6.1 km/h	3.8 mph
Drive speed – raised	0.8 km/h	0.5 mph	0.8 km/h	0.5 mph
Raise/lower speed	30/24 sec		40/37 sec	
Controls	proportional drive		proportional drive	
Tyre width	30.5 cm	12 in	30.5 cm	12 in
Tyre diameter	66 cm	26 in	66 cm	26 in
Gradeability	40%		35%	
Drive	four wheel		four wheel	
Multiple disc brakes	dual rear wheel		dual rear wheel	
Weight	2,971 kg	6,550 lb	3,411 kg	7,520 lb
Weight including outriggers	3,454 kg	7,615 lb	3,894 kg	8,585 lb



A division of FORCE CORP
FREECALL: 1800 674 777