



# Rough Terrain Self-Propelled Scissor Lift

GS™-4390 RT  
GS™-5390 RT

○ Ready to tackle the most rigorous job sites with superior gradeability and traction-controlled four-wheel drive.



**Genie Australia**  
GENIE MEANS MORE THAN LIFTING

## GS-4390 RT & GS-5390 RT

▪ Large platform with durable diamond-plate aluminium flooring. A single 1.52m (60 in) multi-position slide-out extension deck, on the front of the machine, comes standard.

A second 1.22m (48 in) slide-out extension deck, on the rear of the machine, is available as an option.

▪ Rear platform railing can be removed for easier loading and unloading of materials.

▪ Slide-out engine tray allows easy access to components.

▪ Automatic levelling hydraulic outriggers are standard on the GS-5390 RT, optional on the GS-4390 RT.

### Standard Features

- GS-4390 RT has 14.9 m (49 ft) working height and GS-5390 RT has 18 m (59 ft) working height
- 680 kg (1,500 lb) load capacity
- Positive traction-controlled four-wheel drive
- 50% gradeability
- Proportional drive
- Two-speed lift functions
- Troubleshooting diagnostics
- Two self-closing entry gates
- Foam-filled tyres
- AC wiring to platform
- Descent alarm
- Tilt sensor with an audible alarm
- Horn
- Hour meter



### Options and Accessories

- Motion alarm
- Dual flashing beacons
- Propane tank kit (single and/or additional)
- Dual slide-out extension deck package (front and rear)
- Hydraulic oil cooler
- 2,000 watt generator (110 volt/60 hz)
- Automatic levelling hydraulic outriggers (GS-4390 RT)

### Standard Compliance

- ANSI/SIA A92.6
- CSA CAN3-B354.2-M82
- CE compliance option
- AS 1418.10

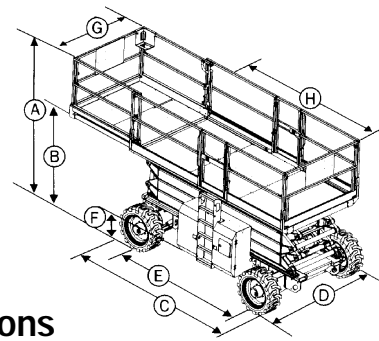

### Specifications

Model	GS-4390 RT		GS-5390 RT	
	Metric	US	Metric	US
Working height	14.9 m	49 ft	18 m	59 ft
Platform height	13.1 m	43 ft	16.2 m	53 ft
(A) Height - stowed				
guardrails	2.93 m	115½ in	3.15 m	124 in
guardrails lowered	2.25 m	88¾ in	2.47 m	97¾ in
(B) Height - stowed (platform)	1.8 m	71 in	2.02 m	79¾ in
(C) Length - stowed				
w/ single deck extension	3.94 m	155¼ in	n/a	n/a
w/ dual deck extension	3.98 m	156½ in	n/a	n/a
w/ outriggers	4.88 m	192 in	4.88 m	192 in
(D) Width	2.29 m	90 in	2.29 m	90 in
(E) Wheelbase	2.92 m	115 in	2.92 m	115 in
(F) Ground clearance	36 cm	14 in	36 cm	14 in
(G) Platform width	1.83 m	72 in	1.83 m	72 in
(H) Platform length				
single deck extended	5.4 m	212½ in	5.4 m	212½ in
dual decks extended	6.57 m	258½ in	6.57 m	258½ in
Slide-out deck extension(s)				
standard front deck	1.52 m	60 in	1.52 m	60 in
optional rear deck	1.22 m	48 in	1.22 m	48 in
Lift capacity	680 kg	1,500 lb	680 kg	1,500 lb
Extension deck cap. (max)	227 kg	500 lb	227 kg	500 lb
Turning radius - outside	5.33 m	210 in	5.33 m	210 in
Turning radius - inside	2.16 m	85 in	2.16 m	85 in
Power source	Ford LRG 425 EFI Gas/LPG 61 kw (82 hp)			
	Deutz Diesel 42 kw (56 hp)			
Auxiliary power unit	12V DC	12V DC	12V DC	12V DC
Drive speed - stowed	8 km/h	5 mph	8 km/h	5 mph
Drive speed - raised	1.1 km/h	0.7 mph	1.1 km/h	0.7 mph
Raise/lower speed	45 sec/39 sec		55 sec/49 sec	
Self-levelling capability				
w/outriggers side/side	12°		12°	
w/outriggers front/rear	7°		7°	
Controls	Two-speed lift and proportional drive			
Tyres	12-21.5 NHS foam filled			
Gradeability (4x4)	50%		50%	
Drive	four wheel			
Multiple disc brakes	dual rear wheel			
Fuel tank capacity	114 litre	30 gal	114 litre	30 gal
Hydraulic tank capacity	114 litre	30 gal	114 litre	30 gal
Weight*	6,250 kg	13,780 lb	8,357 kg	18,425 lb

#### Unit weight modifiers for options

\* Basic unit consists of dual fuel, 4-wheel drive with one extension deck.

GS-5390 RT basic unit includes weight of outriggers.

Diesel	add 45 kg	add 100 lb
Outriggers	add 771 kg	add 1,700 lb
Dual extension decks	add 143 kg	add 315 lb
CE link guard	add 82 kg	add 180 lb



A division of FORCE CORP  
FREECALL: 1800 674 777