



Electric Self-Propelled Scissor Lift

GS™-2668
GS™-3268

○ Large capacity electric scissor lifts with excellent manoeuvrability.



GS-2668 and GS-3268

- Heavy-duty square steel guardrails.
- Large platform with 1.52 m (60 in) roll-out extension and durable diamond plate aluminium flooring.
- High angle steering provides excellent manoeuvrability.
- Swing-out battery tray allows easy access to components.

Standard Features

- GS-3268 has 11.58 m (38 ft) working height and GS-2668 has 9.75 m (32 ft) working height
- 1.52 m (60 in) roll-out platform extension
- 1.73 m (68 in) unit width
- 454 kg (1,000 lb) load capacity for the GS-3268 and 567 kg (1,250 lb) load capacity for the GS-2668
- Proportional drive
- Multiple disc brakes
- Emergency stop switches at platform and ground controls
- Manual brake release
- Full height platform swing gate
- Swing-out battery tray
- Non-marking tyres
- AC wiring to platform
- Tilt sensor with an audible alarm
- Automotive-style horn
- Hour meter

Options and Accessories

- Motion alarm
- 2,000 watt inverter
- Air line to platform
- Platform work lights
- Dual flashing beacon
- Turf tyres
- Rough terrain tyres

Standards Compliance

- ANSI/SIA A92.6
- CSA CAN3-B354.2-M82
- CE compliance option
- AS 1418.10

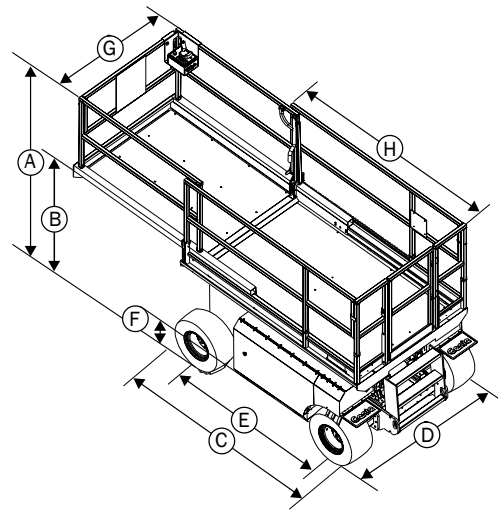

Specifications

Model	GS-2668		GS-3268	
	Metric	US	Metric	US
Working height	9.75 m	32 ft	11.58 m	38 ft
Platform height	7.9 m	26 ft	9.75 m	32 ft
(A) Height - stowed (guardrails)	2.32 m	91½ in	2.45 m	96½ in
Height - stowed (guardrails lowered)	1.7 m	67 in	1.83 m	72 in
(B) Height - stowed (platform)	1.19 m	46¾ in	1.31 m	51¾ in
(C) Unit length - stowed	2.67 m	105 in	2.67 m	105 in
Unit length - platform extended	4.1 m	161½ in	4.1 m	161½ in
(D) Unit width	1.73 m	68 in	1.73 m	68 in
(E) Wheelbase	1.85 m	73 in	1.85 m	73 in
(F) Ground clearance	19 cm	7½ in	19 cm	7½ in
(G) Platform width	1.55 m	61 in	1.55 m	61 in
(H) Platform length - stowed	2.51 m	99 in	2.51 m	99 in
Platform length - extended	3.96 m	156 in	3.96 m	156 in
Roll-out platform extension	1.52 m	60 in	1.52 m	60 in
Lift capacity	567 kg	1,250 lb	454 kg	1,000 lb
Extension deck capacity	136 kg	300 lb	136 kg	300 lb
Turning radius - outside	3.68 m	145 in	3.68 m	145 in
Turning radius - inside	1.52 m	60 in	1.52 m	60 in
Power source	48V (8 6V 350AH batteries), both models			
Drive speed - stowed	5.3 km/h	3.3 mph	5.3 km/h	3.3 mph
Drive speed - raised	0.8 km/h	0.5 mph	0.8 km/h	0.5 mph
Raise/lower speed	30/35 sec		50/37 sec	
Controls	proportional		proportional	
Tyres	23-55 cm	9-21.5 in	23-55 cm	9-21.5 in
Gradeability	30%		25%	
Occupied floor pressure	680 kg/sq.m	166 psf	930 kg/sq.m	192 psf
Tyre contact pressure	593 kPa	86 psi	565 kPa	82 psi
Drive	dual front wheel, both models			
Multiple disc brakes	dual rear wheel, both models			
Weight	2,986 kg	6,583 lb	3,665 kg	8,080 lb



A division of FORCE CORP
FREECALL: 1800 674 777