

TB100J



**Straight Jib
Boom**

Snorkel

www.snorkelusa.com

Snorkel TB100J

Platform	Machine Dimensions	Performance
Height.....100' (30.4 m)	Stowed Length..44'6.4" below (13.6 m)	Power Source.....Gas or Diesel
Size.....96" x 30" (243.8 cm x 76 cm)	Stowed Height 10'4" (3.2 m)	Fuel Capacity.....40 gal (151.4 L)
Capacity.....600 lbs (272 kg)	Wheelbase..... 12' (3.7 m)	Hydraulic Capacity.....90 gal (340 L)
Construction.....Aluminum	Width (axles extended) .. 12'10" (3.9 m)	Drive Speed
	Width (axles retracted)..... 8'6" (2.6 m)	Elevated.....Creep
	Weigh.....33,310 lbs (15,109 kg)	Stowed.....3 mph (4.8 km/h)
	Tire Size.... 15" x 22.5" (38 cm x 57cm)	Gradeability (Theoretical).....56%
		Horizontal Reach.....66' (20.1 m)

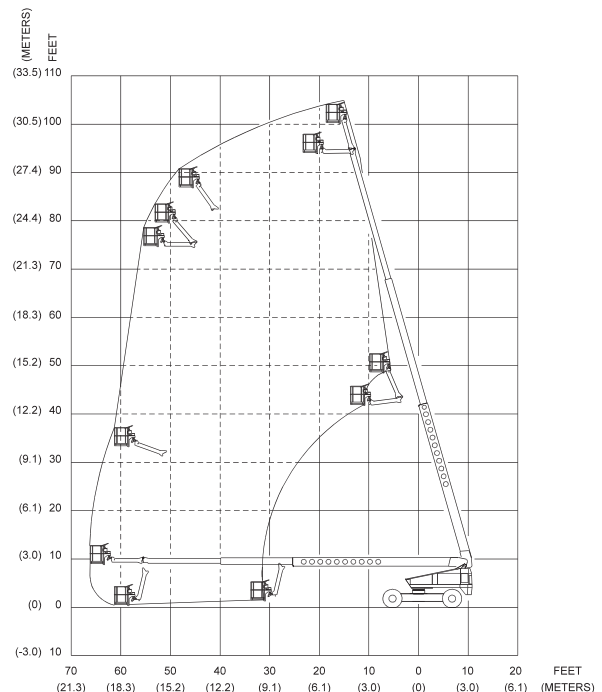
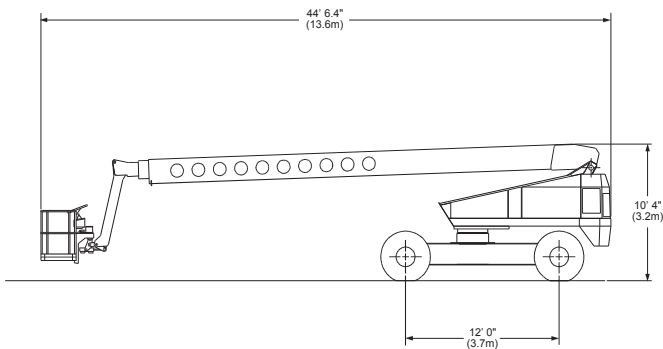

Standard Features

- Foam filled tires
- Built in chassis jack
- Prop. drive, lift, swing, ext. & jib
- Engine anti-restart
- Tie down lugs
- 180 degree hydraulic Platform rotation
- 12 volt emergency power
- Manual bleed down valve
- Hydraulic oil level/temp gauges
- Envelope Management system
- Driveable at full height
- Tilt alarm
- 125 volt GFCI AC outlet
- Aluminum upper booms
- Hour meter
- High engine temp/low oil pressure shut down
- Lifting lugs
- Extendable rear axles
- Operator Horn
- 4-wheel drive & 4-wheel braking

Options

- Platform control box cover
- Flashing light on boom
- Swinging gate
- Sandblast protection kit
- Driving lights
- Platform work lights
- Cold weather start kit
- Two wheel drive option deduct
- Drive motion alarm
- Tow kit
- Airline to Platform
- AC Generator
- Hydraulic Sys. Cold weather Warm-up Kit
- Platform – 96" x 30" (243.8 x 76 cm) Steel 500 lb Cap. (227 kg)
- Platform – 60" x 30" (152 x 76 cm) Aluminum 650 lb Cap. (295 kg)
- Platform – 60" x 30" (152 x 76 cm) Steel 600 lb Cap. (272 kg)

DANGER: Models described in this brochure are NON-INSULATED and do not provide electrocution protection from contact with or close proximity to energized conductors which is pointed out on decals and placards attached to the machine. Only qualified and trained operators are to be authorized to use and operate a work platform. Aerial work platforms must be elevated only on firm, level surface. Products in this brochure comply with applicable ANSI Standards. This literature is for illustrative purposes only. Consult Operating Maintenance and Parts Manuals for proper procedures. Specifications may vary and are subject to change without notice or obligation.

Manufacturing Plant
 2009 Roseport Road
 Elwood, Kansas 66024
 800-255-0317
 785-989-3000

Australia
 26 Redfern Road
 Wetheril Park NSW
 2164 Australia
 (02) 9725 4000