



Self-Propelled Telescopic Boom

S-120/125

- Industry-leading outreach and manoeuvrability.



Genie Industries

S-120/125

Standard Features

- S-120 has 38.4 m (126 ft) working height
- S-125 has 39.9 m (131 ft) working height
- Industry-leading outreach of 22.9 m (75 ft) for S-120, 24.4 m (80 ft) for S-125
- 340 kg (750 lb) lift capacity on the S-120
- 227 kg (500 lb) lift capacity on the S-125
- Four-wheel drive with four-wheel brakes
- Four-wheel steer includes front, rear, crab and coordinated steer functions
- Extendable axles, operated from platform
- Three diesel engine options
- 2.44 m (8 ft) steel platform
- Fully proportional platform controls with ramp up/down feature
- Hydraulic platform rotation
- 360° continuous turntable rotation
- 12V DC auxiliary power

- Closed-loop hydrostatic drive
- Positive traction drive
- Drive enable system
- Self-levelling platform
- Onboard full diagnostics
- Anti-restart engine protection
- Auto engine fault shutdown
- Hydraulic oil cooler
- Engine monitoring display
- Foam-filled tyres
- Wire braided hose
- Tilt alarm
- Horn
- Hour meter

Range of Motion

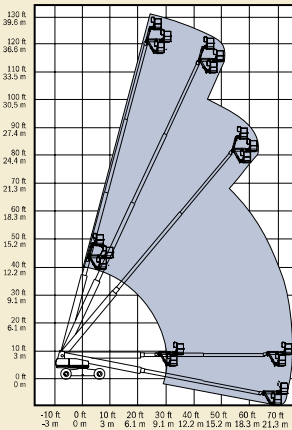

Options and Accessories

- Alarm package
- Cold start packages
- 3500 watt AC generator
- Platform swing gate
- Air line to platform
- Platform rail pinch guard
- Platform work lights
- Hostile environment packages
- Tool tray
- Driving lights

Standards Compliance

- ANSI/SIA A92.5
- CE compliance option
- CAN3-B354.4-M82
- AS 1418.10

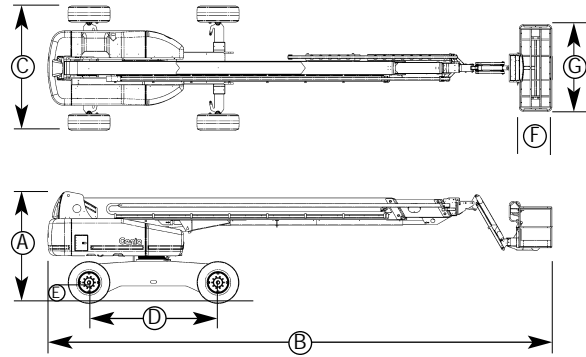

Specifications

Model	S-120		S-125	
	Metric	US	Metric	US
Working height	38.4 m	126 ft	39.9 m	131 ft
Platform height	36.6 m	120 ft	38.1 m	125 ft
Ⓐ Height - stowed	3.07 m	10 ft 1 in	3.07 m	10 ft 1 in
Ⓑ Length - stowed	12.2 m	39 ft 11 in	12.2 m	39 ft 11 in
Ⓒ Width axles retracted	2.6 m	8 ft 6 in	2.6 m	8 ft 6 in
Width axles extended	3.5 m	11 ft 6 in	3.5 m	11 ft 6 in
Ⓓ Wheelbase	3.66 m	12 ft	3.66 m	12 ft
Ⓔ Ground clearance	28 cm	11 in	28 cm	11 in
Ⓕ Platform length	91 cm	36 in	91 cm	36 in
Ⓖ Platform width	2.44 m	96 in	2.44 m	96 in
Horizontal reach max.	22.9 m	75 ft	24.4 m	80 ft
Lift capacity	340 kg	750 lb	227 kg	500 lb
Turning radius - outside	3.2 m	10 ft 6 in	3.2 m	10 ft 6 in
retracted axles 4-wheel steer				
Turntable rotation	360° continuous		360° continuous	
Turntable tailswing	1.68 m	5 ft 6 in	1.68 m	5 ft 6 in
Power source	Cummins 4B3.9 diesel			
	Deutz FL913 diesel			
	Perkins 1004-42 diesel			
Controls	proportional		proportional	
Platform rotation	160° hydraulic		160° hydraulic	
Auxiliary power unit	12V DC		12V DC	
Tyres	18 x 22.5, 18 pr, FF		18 x 22.5, 18 pr, FF	
Hydraulic tank capacity	208 litre	55 gal	208 litre	55 gal
Fuel tank capacity	151 litre	40 gal	151 litre	40 gal
Drive speed, stowed	4.8 km/h	3 mph	4.8 km/h	3 mph
Gradeability, stowed	40%		40%	



A division of FORCE CORP
FREECALL: 1800 674 777