



## Self-Propelled Telescopic Booms

S-60/S-65

- With unique out-and-up jib option.



# The Genie S-60 and S-65 are the value leaders in the industry.

Genie's redesigned stick boom family includes faster lift speed, a more powerful engine, a stiffer mast and updated styling. Choose the Genie S-60 boom, with 20.1 m (66 ft) of working height, or the S-65, with an additional 1.52 m (5 ft) articulating jib boom. Customise your boom from many option packages.



## S-65 Out-and-Up Articulating Jib Boom

This special option gives you an additional 1.52 m (5 ft) of horizontal reach for a total of 17.2 m (56 ft 4 in). The S-65 jib boom gives you flexibility too – 135° of working range. You not only access 75° above horizontal, but you can get to 60° below horizontal.

## Standard Features

### Proportional Controls

Allow smooth operation and easy positioning.

### 160° Hydraulic Platform Rotator

Gives you precise placement without repositioning the boom.

### Easily Accessible Components

The swing-out engine tray and easy-to-understand electrical system simplify routine maintenance.

### Positive Traction Drive and Oscillating Axle

Full-time positive traction system and oscillating axle on both 4x2 and 4x4 models.

### Drive Enable System

Informs operator when the drive and steer functions will move opposite the controller movements.

### Low-Profile Chassis Covers

Provide high visibility for the operator while unit is in stowed position.

### Platform Controls

Large, simple-to-use controls for easy operation.

### Transportability

The S-60 and S-65 are designed to load and unload easily from transport vehicles.

### Increased Lift Speed

The capability to operate multiple functions simultaneously results in maximum lift speed. The S-60 elevates from the ground to full height in just 57 seconds.

### Stiffer Mast Design

The new flat-bottom mast design is 7% stiffer than before when fully extended. The stiffer mast results in less platform movement for more comfortable operation.



**Easily customised to meet your needs:**

**Engine Options**

- Ford LRG 425 EFI  
Gas/LPG 61 kw (82 hp)
- Deutz Diesel F4L 1011  
42 kw (56 hp)
- Perkins Diesel 704-30  
45 kw (60 hp)

**Platform Options**

- Standard: Steel 1.83 m (6 ft)
- Optional: Steel 2.44 m (8 ft)

**Drive Options**

- 4x2 – two wheel drive  
gradeability up to 30%
- 4x4 – four wheel drive  
gradeability up to 40%

**Tyre Options**

- Rough terrain foam-filled
- Rough terrain air

**Terrain Tracking Active Oscillation System**

This revolutionary system automatically senses the terrain and adjusts the axle position based on ground conditions. The standard oscillating axle allows you to drive on uneven ground with the turntable rotated up to 90°. It provides an amazingly smooth ride even when the platform is raised.



**Powerful Gas Engine**

The new Ford LRG 425 Electronic Fuel Injection Gas/LPG 61 kw (82 hp) engine is stronger and more powerful than before, with enhanced performance in high altitude and cold weather environments. The fuel-injection system requires less service work than carburettor systems, eliminating the need for throttle linkage and choke adjustments.





## Standard Features

- S-60 has 20.1 m (66 ft) working height
- S-65 has 21.6 m (71 ft) working height
- S-60 has 15.6 m (51 ft 3 in) horizontal
- S-65 has 17.2 m (56 ft 4 in) horizontal
- Up to 272 kg (600 lb) lift capacity on the S-60
- 227 kg (500 lb) lift capacity on the S-65
- Oscillating axle system
- Dual extended cylinders
- Dual fuel (Gas/LPG) or diesel engine options
- Fully proportional platform controls with ramp up/down feature
- Hydraulic platform rotation
- 360° continuous turntable rotation
- 12V DC auxiliary power
- Fuel select switch on platform and ground control panels (Gas/LPG models)
- Closed-loop hydrostatic drive
- Positive traction drive
- Drive enable system
- Self-levelling platform
- Rough terrain foam-filled tyres
- Locking turntable covers
- Anti-restart engine protection
- Auto engine fault shutdown
- Engine monitoring gauges
- AC wiring to platform
- Wire braided hose
- Tilt alarm
- Horn
- Hour meter

## Range of Motion

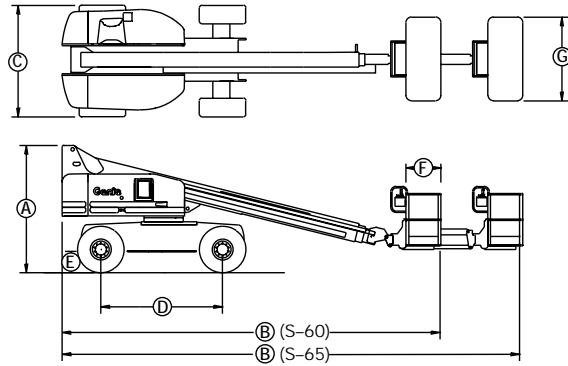
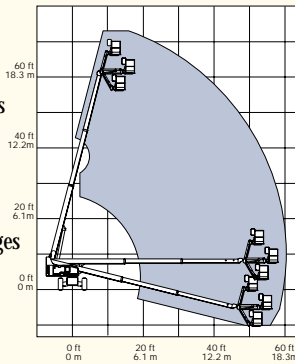

## Specifications

Model	S-60		S-65	
	Metric	US	Metric	US
Working height max	20.1 m	66 ft	21.6 m	71 ft
Platform height max	18.3 m	60 ft	19.8 m	65 ft
Ⓐ Height - stowed	2.74 m	9 ft	2.74 m	9 ft
Ⓑ Length - stowed	8.3 m	27 ft 2 in	9.4 m	30 ft 10 in
Ⓒ Width	2.44 m	8 ft	2.44 m	8 ft
Ⓓ Wheelbase	2.74 m	9 ft	2.74 m	9 ft
Ⓔ Ground clearance	30 cm	12 in	30 cm	12 in
Ⓕ Platform length: 6 ft	76 cm	30 in	76 cm	30 in
8 ft	91 cm	36 in	91 cm	36 in
Ⓖ Platform width: 6 ft	1.83 m	72 in	1.83 m	72 in
8 ft	2.44 m	96 in	2.44 m	96 in
Horizontal reach max	15.6 m	51 ft 3 in	17.2 m	56 ft 4 in
Maximum lift capacity 6 ft platform	272 kg	600 lb	227 kg	500 lb
Maximum lift capacity 8 ft platform	227 kg	500 lb	227 kg	500 lb
Turning radius - outside	6.76 m	22 ft 2 in	6.76 m	22 ft 2 in
Turning radius - inside	3.68 m	12 ft 1 in	3.68 m	12 ft 1 in
Turntable rotation	360° continuous		360° continuous	
Turntable tailswing	1 m	3 ft 3 1/2 in	1 m	3 ft 3 1/2 in
Power source	Ford LRG 425 EFI Gas/LPG 61 kw (82 hp) Deutz Diesel F4L 1011 42 kw (56 hp) Perkins Diesel 704-30 45 kw (60 hp)			
Controls	12V DC proportional		12V DC proportional	
Platform rotation	160°		160°	
Tyres	15 - 19.5 NHS		15 - 19.5 NHS	
Hydraulic tank capacity	170 litre	45 gal	170 litre	45 gal
Fuel tank capacity	125 litre	33 gal	125 litre	33 gal
Weight	11,821 kg	26,060 lb	12,882 kg	28,400 lb
S-60 and S-65	4x2		4x4	
Drive speed - stowed Gas/LPG models	7.1 km/h	4.4 mph	4.8 km/h	3 mph
	12.2 m/6.2 sec	40 ft/6.2 sec	12.2 m/9.1 sec	40 ft/9.1 sec
Drive speed - stowed Diesel models	6.4 km/h	4 mph	4.5 km/h	2.8 mph
	12.2 m/6.8 sec	40 ft/6.8 sec	12.2 m/9.7 sec	40 ft/9.7 sec
Drive speed, raised or extended (all models)	1 km/h	0.6 mph	1 km/h	0.6 mph
	12.2 m/40 sec	40 ft/40 sec	12.2 m/40 sec	40 ft/40 sec
Gradeability - stowed	30%		40%	

## Options and Accessories

- Alarm package
- Cold start packages
- 2,500 or 3,000 watt AC generator
- 2.44 m (8 ft) steel platform
- 340 kg (750 lb) lift capacity option on the S-60
- Platform swing gate
- Air line to platform
- Platform rail pinch guard
- Platform work lights
- Lockable platform control box cover
- Tool tray
- Fluorescent tube caddy
- Hostile environment packages
- Hydraulic oil cooler
- Additional LPG tank
- GS/LPS rating for Ford engine powered machines
- Rough terrain air tyres
- Driving lights
- Pipe cradle

## Standards Compliance

- ANSI/SIA A92.5
- CSA CAN3-B354.4-M82
- CE compliance option
- AS 1418.10



A division of FORCE CORP  
FREECALL: 1800 674 777